



## ADJUSTABLE BOLTS

### Functions

Bolt for second sash, featuring zamak terminals that enable secondary sash closing compression adjustment.

### Technical Features

Specifically designed for use on overlap profiles with double channel. It is fitted in the profile groove without machining and, after obtaining the correct positioning, fixed by tightening the grub screw pre-assembled on the fixing block.

The terminal is entirely in zamak and has a zamak bolt tip enabling  $\pm 1.5$  mm adjustment in the closed position.

The supplied connecting plate can be replaced by the GIESSE o series connecting bracket if the mechanism is to be sited in a non-standard position. The body of the terminal is equipped with vibration-damping leaf springs.

### Adjustment

For adjustment, using a 2.5 mm Allen key just slacken the screw holding the terminal and bolt tip together, turn the bolt tip one or more steps in the required direction, then tighten the screw. Every step corresponds to a recovery of approx. 0.3 mm.

### Materials

Mechanism and connecting element in polyamide. Terminal and fixing plug in stainless steel or zamak depending on the model.

Screws and grub screws in stainless steel.

Article 02168K - 02166K

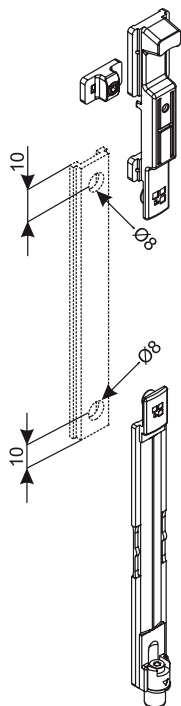

Article 02008

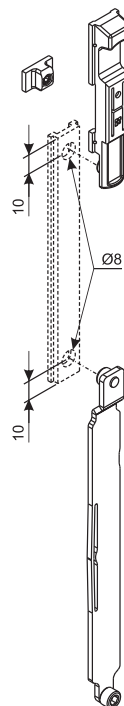

Adjustment Article 02168K - 02166K

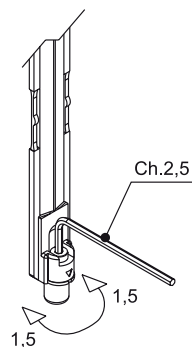

Adjustment Article 02008

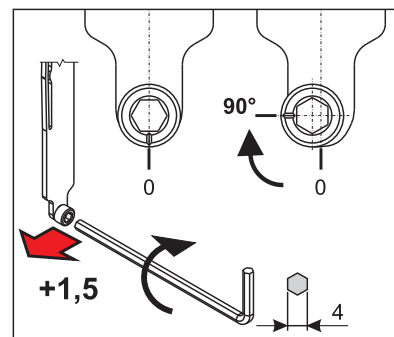

Item code	Description	PROFILE CROSS - SECTION	Groove (mm)	Terminal	Base Raw	Anodised Elox	Painted	Trend/Gold Brass	Pieces per pack
02166K	FUTURA ADJUSTABLE BOLT	-	13,2 ÷ 16,8	Zamak	X				10
02168K	FUTURA ADJUSTABLE BOLT	-	15 ÷ 20	Zamak	X				10